



LP GAS

REGULATOR

BS EN 13786

MODEL 6020
PI.0~15.6
Q6.R280

FOR OUTDOOR USE
INSTALL UNDER A PROTECTIVE COVER

WINNTEC
CORPORATION
U.S.

VENT

WINNTEC

G A S A P P L I A N C

Instruction Manual Model 6020 Automatic Change Over Regulator

- 4 Mounting Screws
- 1 Mounting Bracket
- Pigtails (2 per set)
- 1 Protective cover

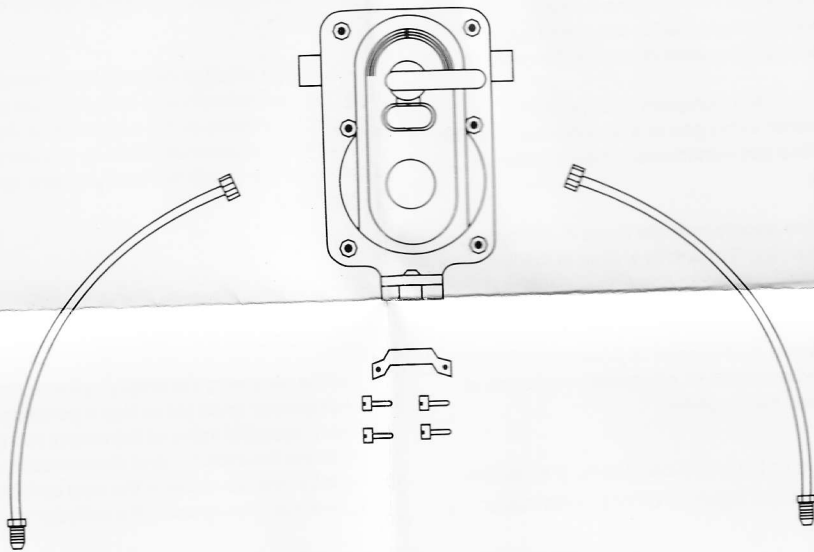

TECHNICAL SPECIFICATION

Capacity	210, 000 Btu/hr
Inlet	25-250 psig
Outlet	11"W.C.

INSTALLATION INSTRUCTIONS for MODEL 6020 AUTO CHANGE OVER REGULATOR

1. Remove all parts carefully from the carton and attach the bracket to the underside of the regulator with two self tapping screws supplied.
2. Mount the regulator and bracket in suitable position firmly with screws supplied.
3. The outlet thread on the regulator is 3/8" SAE Flare and care should be taken to ensure clean and suitably sealed fittings are attached firmly.
4. The two pigtail hoses should be attached one either side of the auto changeover valve. Attach the TYPE I ends of the pigtail hoses one to each cylinder.
5. Ensure all appliances are turned off prior to the following tests being carried out.
6. If problems are encountered whilst connecting the device to the cylinder valve consult your dealer.

Instruction Manual

Model 6020

Automatic Change Over Regulator

WARNING

The Model 6020 must be installed, operated and maintained in accordance with federal, state and local codes. The installation in most states must also comply with LPGA Codes of Practice.

Things to tell the Gas Customer

1. Point out the regulators vent to the customer, and stress that this opening must remain unobstructed at all times. Tell the customer to be sure to check the vent opening after a freezing rain, sleet storm, or snow to make sure ice has not formed in the vent.
 2. Show the customer the shutoff valves on the cylinders. The customer should close these valves immediately if gas can be smelled, appliance pilot lights fail to stay on or appear higher than usual, or any other abnormal situation occurs.
 3. Tell the customer to call your company to service the regulator. If the regulator vents gas or a leak develops in the system, only a qualified gas serviceman should install or service the regulator.
 4. Inform the user that the supply cylinder is not completely empty until the red warning flag is fully visible in the indicator window.
- If the device is enclosed in unvented compartment the relief valve must be vented outdoors or adequate ventilation of the compartment must be supplied.
 - When the device is to be used outdoors, it shall be positioned or protected against direct penetration by any trickling water.

Description

The model 6020 regulator is designed for low-pressure 11"W.C. vapor service and is not to be used for liquid service.

The unit withdraws gas from one cylinder until pressure drops to 10psig and then automatically switches to the reserve cylinder.

This unit is for propane use only and only for 2 cylinder systems

Important

Only qualified persons should install, adjust or service LP gas regulators, if service is needed, contact your original dealer or a qualified LP dealer. Always make sure cylinders are properly filled and never accept cylinders that are over filled. When replacing newly filled cylinders to the regulator, check all connections for leaks with an approved leak detector solution or a mixture of non-ammonia soap and water. Never use matches or an open flame. Note: Low pressure regulators are designed to regulator LP vapor only.

Operation

Place one of the two cylinders in "supply" by rotating the changeover lever(A) either way as far as it will go. The arrow will denote the "supply" service side. Open both cylinder valves slowly.

Gas will now flow from both cylinders through the pigtailed into the model 6020 by way of the inlet fittings. When a pressure of 10 psig is reached beneath the 6020 diaphragm, the closing spring in the inlet fitting will shutoff gas from the "reserve" cylinder.

The "Supply" side of the regulator will continue to supply gas as long as sufficient gas remains in the "supply" cylinder. When pressure in the cylinder drops to about 10 psig, the "reserve" side of the regulator will open and continue to regulate at 11"W.C. At the time the "supply" cylinder becomes exhausted, a red warning flag appears in the indicator window. This red flag indicates that a cylinder exchange can be made.

If a leak is smelt or detected the cylinders should be turned off at the handwheel valve and your gas supplier consulted. Never search for leaks with a naked flame. Always use a soapy solution, bubbles will show up around the area of the leak. Never try to repair the leak yourself, always call a registered gas fitter.

Exchange of cylinders

Before removing the empty cylinder, be sure to rotate the changeover lever (a) so that it points to the other cylinder. Then close the valve of the empty cylinder to prevent air from entering the cylinder and disconnect the cylinder. Clean the cylinder valves outlet in the new cylinder. After the new cylinder is in place, slowly open the cylinder valve.

CAUTION

There will still be pressure in the empty cylinder.

The new cylinder now becomes the reserve cylinder, and the red warning flag will not be visible at the indicator window. If only one cylinder is left connected, the pigtail or hose to the other cylinder must be capped to prevent leakage or contamination.

Maintenance

To avoid personal injury or equipment damage, do not attempt any maintenance or disassembly without first isolating the regulator from system pressure and relieving all internal pressure.